

Scanned by Lynn Bisha W2BSN

Courtesy of the
Antique Wireless Association's
Museum of Electronic Communications
Bloomfield New York

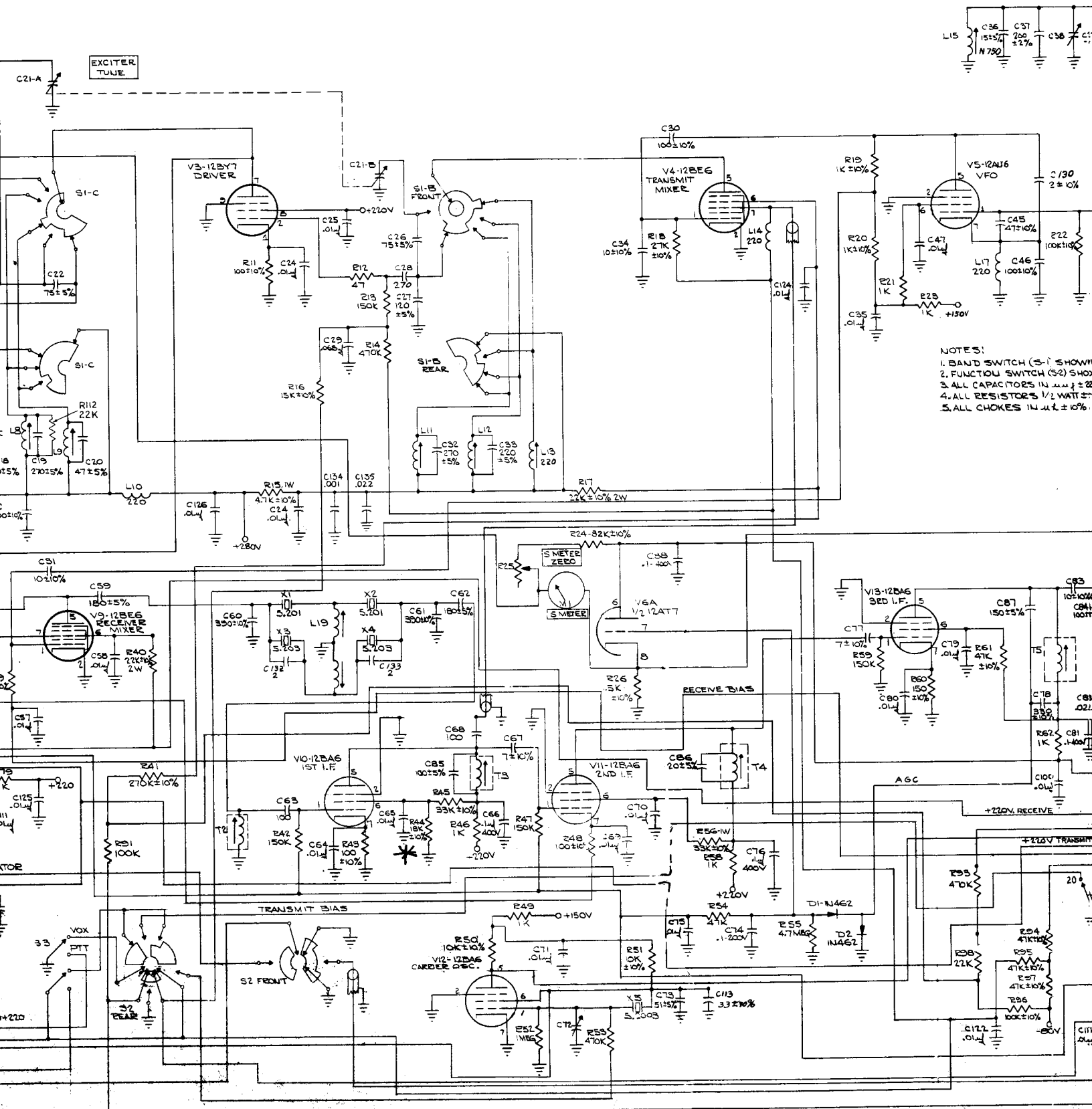

- NOTES:
 1. BAND SWITCH (S-1) SHOWN
 2. FUNCTION SWITCH (S-2) SHOWN
 3. ALL CAPACITORS IN μF UNLESS OTHERWISE SPECIFIED
 4. ALL RESISTORS 1/2 WATT UNLESS OTHERWISE SPECIFIED
 5. ALL CHOKES IN μH UNLESS OTHERWISE SPECIFIED

* R44 removed per letter from National

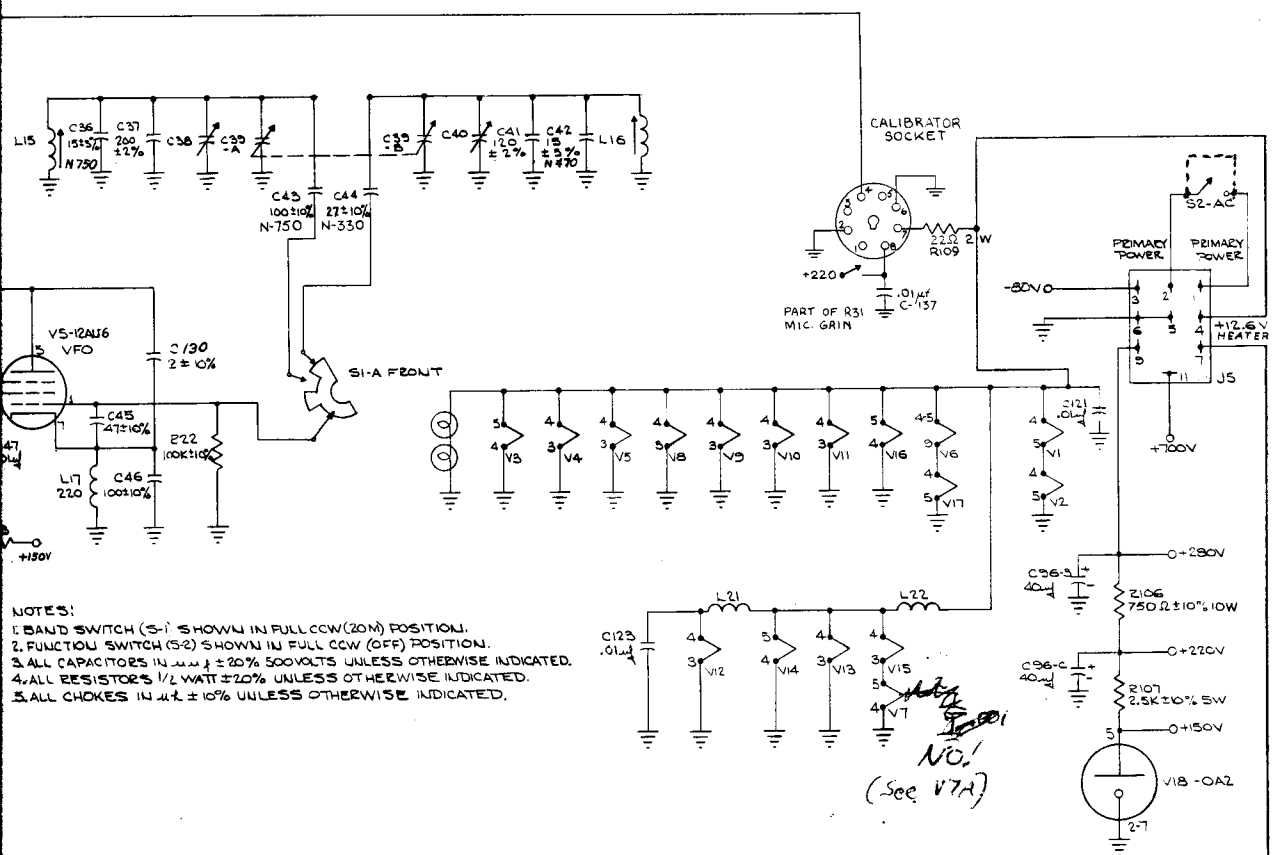

- NOTES:
1. BAND SWITCH (S-1) SHOWN IN FULL CCW (20M) POSITION.
 2. FUNCTION SWITCH (S-2) SHOWN IN FULL CCW (OFF) POSITION.
 3. ALL CAPACITORS IN μ F \pm 20% 500VOLTS UNLESS OTHERWISE INDICATED.
 4. ALL RESISTORS 1/2 WATT \pm 20% UNLESS OTHERWISE INDICATED.
 5. ALL CHOKES IN μ H \pm 10% UNLESS OTHERWISE INDICATED.

NO. 1
(See V7A)

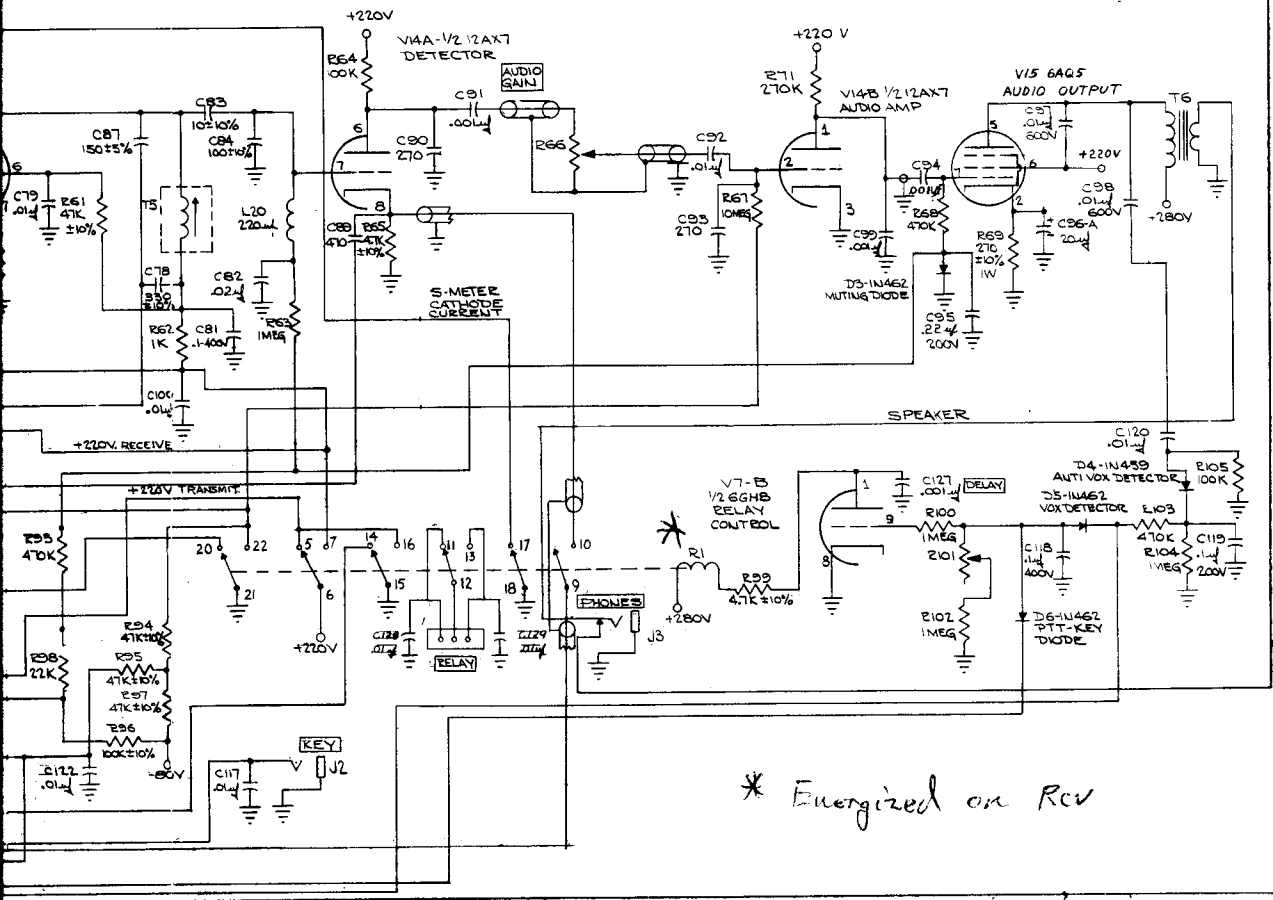

* Energized on Rcv

NATIONAL RADIO COMPANY, INC.

A WHOLLY OWNED SUBSIDIARY OF NATIONAL CO., INC.



ESTABLISHED 1914

TEL. NORMANDY 5-4800
CABLE ADDRESS "NATCO" BOSTON

37 WASHINGTON STREET
MELROSE 76. MASS.

Dear O. M. :

We'd like to thank you for purchasing the NCX-3 transceiver, and at the same time provide you with a few hints and kinks which will help you to get even more enjoyment out of your new rig:

1. First of all, please mail your warranty card immediately, since as soon as it is received you will be placed on our NCX-3 customer service list to keep you immediately informed of forthcoming accessories, modifications or improvements, service notes etc.
2. Choice of microphone is important, since the NCX-3 is designed to provide the smoothest, cleanest audio possible. All necessary filtering and restriction of audio bandwidth is done in the NCX-3, and a so-called "restricted" or "communications quality" microphone will undo this design feature. Avoid ceramic or crystal microphones designed for Citizens Band use, since these mikes are usually designed to sell for a price -- and sound like it. Use the best microphone you can afford -- preferably a flat, wide range dynamic. We've found the Electro-Voice 664 and Shure 545 to be extremely good for fixed station use, although relatively expensive, and the Shure 10-4 dynamic and the new EV 600E are excellent for mobile application.
3. PA screen current is one of the best indicators of proper operation of the NCX-3, and since there is no separate screen meter in the NCX-3, an excellent substitute is the VR tube at the rear of the chassis. Should the final amplifier be operating improperly, excessive screen current will be drawn by the 6GJ5's which will cause sufficient voltage drop in the +280V bus to extinguish the VR tube (and simultaneously remove all oscillator regulation). The VR tube should stay lit with full carrier inserted during tune-up, and should not extinguish on SSB voice peaks. Typical reasons for VR tube trouble are insufficient loading, excessive microphone gain, low primary voltage to the power supply (low line voltage with the NCX-A, low battery voltage under idling or engine-off conditions with the NCX-D), or use of an improper power supply. It's always a good idea to glance at the VR tube after loading up on a new band to make certain everything is O. K. Caution: Do not attempt to transmit with the NCX-3 if the VR tube indicates a malfunction, since the result will be distortion, frequency shift, non-linearity etc. A quick check of the above trouble areas will show where the difficulty lies.

Again, thank you for buying National, and we will welcome your comments on your new NCX-3.

73,

Mike Ferber, W1GKX
Equipment Sales Manager

MF:chc



tuned to tomorrow

DESIGNERS AND MANUFACTURERS OF PRECISION COMMUNICATION EQUIPMENT AND COMPONENTS



CUSTOMER SERVICE BULLETIN

July 7, 1964

To: All NCX-3 Customers

Subject: NCX-3 Suggestions &
Operational Hints

Sales Bulletin: CIB-64-9

Dear NCX-3 Customer:

In the little over one year since the NCX-3 was introduced, we have found that some operating questions or difficulties seem to pop up more frequently than others. We must assume that other NCX-3 customers (besides the ones that we hear from) have the same questions but do not bother to write us, and so this bulletin is intended to cover all of these most frequently recurring questions at one fell swoop. Naturally, we recommend that if you are not encountering any of these "problems," that you leave the rig alone! These suggestions are only to remedy existing difficulties in specific units - NOT necessary or recommended where no trouble presently exists.

1. R.F. FEEDBACK

Some microphones being used with the NCX-3, especially those using "coil cord," have a tendency to introduce RF feedback into the NCX-3 through the microphone preamplifier. The RF feedback usually shows up after you have had the NCX-3 fully loaded and start to increase the Mic Gain Control. Suddenly you will find that the plate meter will jump up to 300 ma without audio input, and many times the oscillation can be heard on the signal. This feedback may also manifest itself by the "breaking up" of the transmitted audio when the Mike Gain is advanced beyond a certain point. We have found that simple bypassing will eliminate this RF feedback. We suggest the following:- Add a .003MF/500 volts DC capacitor from the hot side of the Mic Jack to ground. Add a .001 MF/500 volts capacitor from pin #2 of V7A, which is 1/2 of the 6GH8, to ground. If your NCX-3 uses the 6AN8 in place of the 6GH8, the correct pin connection for the 6AN8 is pin #8.

If the RF feedback persists, add an additional .001MF/500 volts from pin #2 of the V6B, which is 1/2 of the 12AT7 speech amplifier, to ground. The leads for these capacitors should be as short as possible.

(Over)

2. VOX ADJUSTMENT

It would appear that there is a general tendency to set the VOX sensitivity much too high, and there are two undesirable results. The first, of course, is lack of anti-vox action, and the second is interaction between the VOX sensitivity and the VOX delay controls. This interaction will create erratic VOX delay operation. We suggest that VOX sensitivity control be set so that it just trips the VOX circuit when the microphone is close talked, and the VOX Delay Control is set for minimum delay. (In VOX operation the microphone should be no further than two inches from your lips under normal speech conditions.) When you stop speaking, the NCX-3 should go back into the receive mode in approximately one tenth of a second. Then adjust the VOX delay control clockwise for proper delay to suit you. When the above procedure is followed, the VOX circuit should operate with little or no interaction of the controls. However, if you continue to experience difficulty, it would be advisable to check the VOX diodes - D4, D5, and D6. These should have a back resistance of approximately two megohms when one end is removed from the circuit. If you find that they are defective, we will be more than happy to replace them for you at no charge.

3. VOX RELAY "HANG-UP"

A small AC voltage (hum) may be fed into the NCX-3 when insufficiently shielded microphones are used, thereby causing erratic operation in the VOX mode. This erratic operation shows up in the form of chattering or hanging-up of the relay, and it can be prevented if the following simple change is made in your NCX-3:- There is a yellow wire which runs from the VOX-PTT switch on the rear apron of your NCX-3 to the mode switch on the front panel. If this yellow lead is replaced with a shielded lead, with the shield grounded, this condition is eliminated, and normal VOX operation can be obtained.

4. OCCASIONAL COMPLAINTS OF VOX "HANG-UP."

This can, in many cases, be traced to unusually high negative bias voltage from the power supply. We recommend that the bias voltage for the NCX-3 be minus 80 volts, and stress that if you are using a power supply other than the NCX-A that you very carefully check the bias voltage and make sure that it is only minus 80 volts. Even the NCX-A and NCX-D power supplies can provide higher bias voltage if primary voltage to the supply is high, and in such instances resistance should be connected in series with the bias line from the power supply to the transceiver until the bias voltage is corrected.

5. NCX-D INPUT VOLTAGE

The NCX-D power supply is designed and guaranteed for a nominal input voltage of 12.6 V.D.C., with a maximum excursion of 11.5 to 14.0 volts. Input voltage higher than 14.0 volts under either transmit or receive conditions will permanently damage the power transistors.

We strongly recommend that you check your generator system for proper output voltage before connecting the NCX-D (or any other transistorized supply), and if the output voltage under either idling or high speed engine conditions is greater than 14.0 volts, have it adjusted to no more than 13.5 V.D.C. before installing the NCX-D power supply. If your NCX-D is already installed and operating, check the generator voltage anyway to avoid possible future failure.

6. MOBILE NOISE

We have had many inquiries requesting our suggestions in reducing mobile noise. We have found that the easiest and the biggest single improvement is the addition of resistor type spark plugs - not suppressors outside the plugs. In most cases this will reduce the noise to tolerable levels. Also, a normal check of the distributor condensers should be made and the proper bonding of the tail pipe to the frame should be checked.

If mobile noise persists, it is suggested that you consult the ARRL Mobile Guide or a competent mobile communications serviceman, preferably one who has had experience in installing mobile equipment, for further suggestions.

7. ADDITIONAL VOX DELAY

We have found that a number of people would like additional VOX delay capabilities in their NCX-3, and to accomplish this, we suggest that you change C118 from .1MF to .25MF.

8. TRANSMIT-RECEIVE "CLICK"

When switching from receive to transmit with the NCX-3, some units may generate an objectionable "pop" or "click" in the loudspeaker. This noise is usually caused by switching transients within the NCX-3, and if it is objectionable in your unit, it can be reduced as follows:- On the transmit receive relay, there is an additional contact marked pin #19. If a lead is run from this contact to pin #5 of the Jones Power Plug, which is on the rear apron of your NCX-3, and then very carefully dressed along the inside edge of the underside of the chassis, it will provide you with a ground for the speaker leads. This lead should follow the cable harness that runs to the relay as closely as possible and should be kept very close to the harness. If care is not taken, carrier leakage could develop.

(Over)

9. CLEANING THE PANEL

A number of people have inquired concerning the best method of cleaning the front panel. We have found that washing the panel with a soft cloth and a mixture of liquid detergent (such as Joy, or any dishwashing detergent) will do an excellent job. Also, cleaning with an alcohol base solution, such as wood alcohol or rubbing alcohol, will also do an excellent job. NEVER use an ether keytone base material, such as acetone.

These suggestions cover all the significant information available on the NCX-3. However, should you experience any particular problem, we hope that you will not hesitate to contact us for assistance.

73's

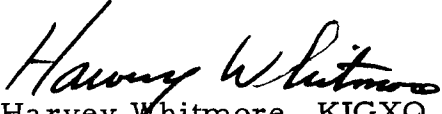
Harvey Whitmore, KIGXO
Customer Service Manager

HW:bb

NCX-A POWER SUPPLY

(115-230 VOLT)

This NCX-A Power Supply contains provision for 230 volt AC operation. Selection of 115 volt or 230 volt operation may be made by use of the transfer switch internally mounted on the chassis. The supply has been shipped with the transfer switch in the 115 volt position.

Power input ratings are as follow:

- 115 volt AC $\pm 10\%$, 50-60 cycles
- 1.4 amperes, 140 watts ---- receive
- 3.7 amperes, 365 watts ---- PEP transmit
- or
- 230 volt AC $\pm 10\%$, 50-60 cycles
- 0.7 amperes, 140 watts ---- receive
- 1.9 amperes, 365 watts ---- PEP transmit

SPECIAL NCX-A PARTS

(115-230 VOLT)

Transformer, Power	C51325
Switch, Transfer	B27662

NCX-A SCHEMATIC

(115-230 VOLT)

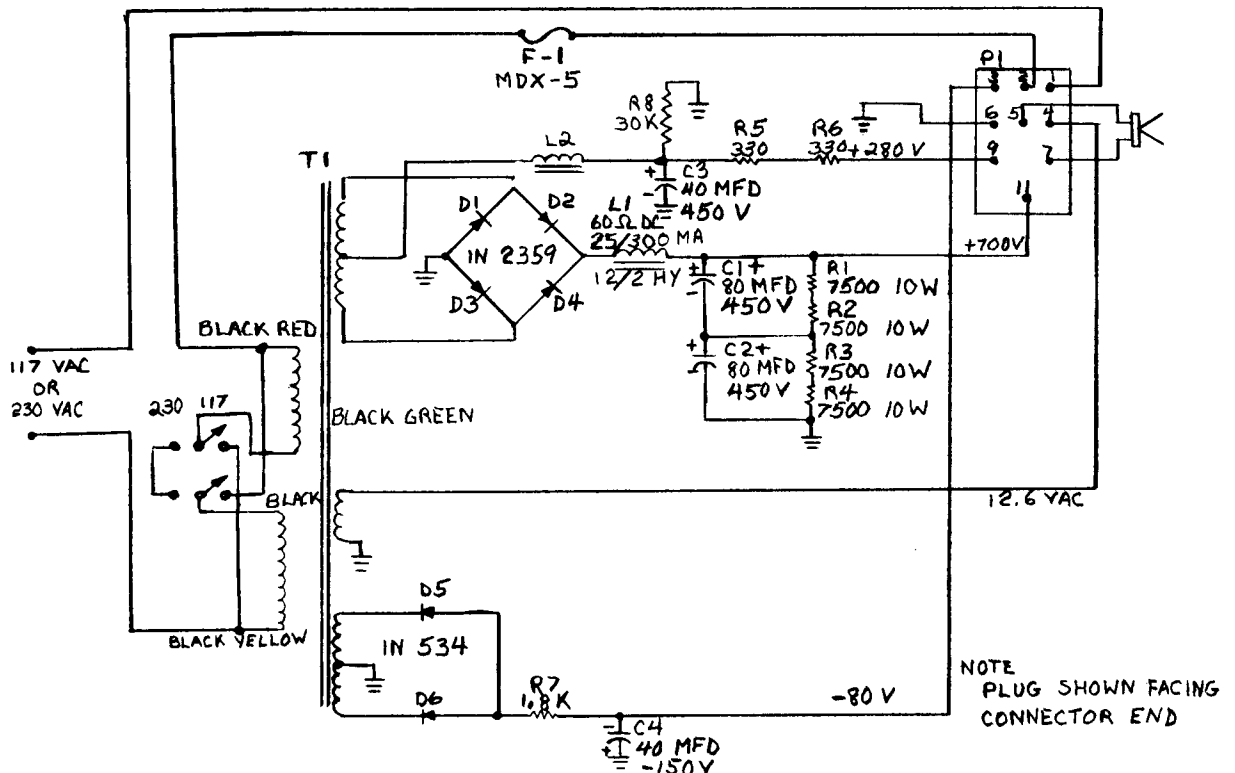

MODEL NCX-A and NCX-D

ADDENDA SHEET

MODEL NCX-A

1. Resistor R7 has been changed from $1000 \Omega \pm 10\%$ to $1800 \Omega \pm 10\%$.
2. A 0.01 uf 600 volt capacitor from one side of the AC line to chassis is not indicated on the schematic.
3. A revised primary power schematic is shown below:

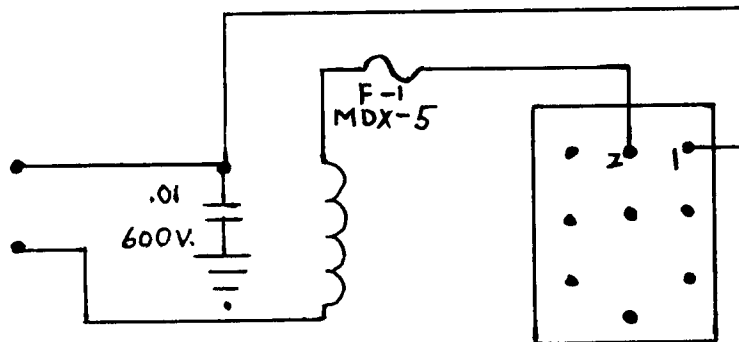

MODEL NCX-D

1. A 0.25 uf 600 volt capacitor has been added from terminal 4 to terminal 8 of the power transformer.

NCX-3 ADDENDA SHEET

1. R107, $2500 \Omega \pm 10\%$ 5 watt, has been changed to $3900 \Omega \pm 10\%$ 10 watt and is connected directly from pin 9 of the power plug to pin 5 of V18-0A2.
2. C120, .01 μf , has been eliminated.
3. C18, $240 \mu\text{f} \pm 5\%$, has been changed to $220 \mu\text{f} \pm 5\%$.
4. R10, $8200 \Omega \pm 10\%$, has been changed to $4700 \Omega \pm 10\%$.
5. A capacitor labeled C22, $75 \mu\text{f} \pm 5\%$, located on the schematic just below switch S1-C, should be identified as C139.



CUSTOMER SERVICE BULLETIN

May 31, 1966

NCX-3
CSB 66-2

National Radio Customer Service Bulletins are provided free to all registered owners of our equipment. Information contained herein is gathered from our factory and field service organizations as well as from National owners.

We do not recommend the "automatic" incorporation of modifications except when the trouble description is identical to your problem, or when suggested for preventive maintenance.

CHIRP ON CW

It has been brought to our attention that some NCX-3's exhibit chirp on CW. This is due to an RF voltage being fed back to the voltage regulator tube, V-18.

The above condition can be eliminated as follows:

Remove the red wire from Pin 1 of V-18 and reconnect to Pin 6. Add a 2.5mh 50ma RF choke between Pins 1 and 6. Add a .01 uf discap from Pin 6 to ground. Solder all connections.

IMPROVED NEUTRALIZATION AT 3.5 Mc

a.) Place a solder lug under the holding screw of C-17, nearest the driver coils. Remove the ground end of C-138 from V-2 ground ring and reconnect to the new lug. Dress this capacitor flat against the chassis.

b.) Redress R-5 flat against the chassis so that it does not "look" into the plate circuit through the ventilation holes. It may be necessary to splice a wire to R-5 so that it lies flat.

c.) Move C-23 from top of terminal strip down into the rivet holes and place close against sub-chassis. Place coax grid drive lead in lower hole also, and tuck under cable harness.

(over)

NCX-3 (cont.)

d.) The correct setting of C-17 must be determined at 14. 2 Mc. It should now be possible to get full output, or very close to it, at the dip at 3. 5 Mc.

IMPROVED RECEIVER SENSITIVITY
AND GRID DRIVE

Remove R-44 at the screen grid of V-10. Do not replace.

IMPROVED TRACKING OF 80 METER
GRID DRIVE

Change C-18 from 240pf to 220pf 5%. Repeak 80 meter driver coil.

IMPROVED RECEIVING AUDIO QUALITY
ON SSB

Change C-82 from . 01 to . 02uf.

INCREASED DRIVE AND RELIABILITY

We have found that changing the driver tube from 12BY7 to 6GK6 results in improved reliability and greater drive. The following changes are necessary in order to substitute the 6GK6:

- a.) Change R-11 to 100 ohms 1 watt.
- b.) Change R-13 to 100K ohms 1/2 watt.
- c.) Change V-4 to a 6BE6.
- d.) Remove the ground from Pin 3 of V-4.
- e.) Locate the brown wire going from Pin 4 of V-4 to Pin 5 of V-3. Remove from Pin 4 of V-4 and reconnect to Pin 3 of V-4. Connect a 12 ohm 10 watt resistor from Pin 4 of V-4 to Pin 5 of V-3.

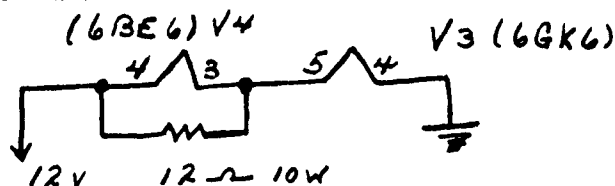

- f.) It will be necessary to repeak all driver and mixer coils.

(over)

NCX-3 (cont.)

INCREASED PERFORMANCE

NCX-A supplies with serial numbers beginning with 44, 49, 57, 63, 69, or 72 may be modified for increased output.

The modification may be easily made by connecting a 660 ohm 10 watt resistor in parallel with the two 330 ohm 10 watt resistors R-5 and R-6 in the NCX-A supply. Designate the new resistor R-9.

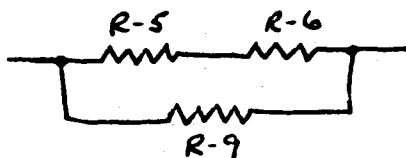

With this modification, the NCX-3 and the NCX-5 may be used with the same supply.

NCX-A supplies with serial numbers beginning 73 or higher have this resistor added at the Factory.

Service Department
NATIONAL RADIO COMPANY

Technical Services Section

CWH:vfl

Distribution: All NCX-3 Owners
List "L"
List "F"

C. W. Huether K1UHY/K2QJM
Service Manager